

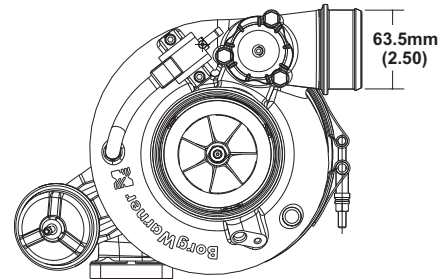

### Turbo Frame Dimensions



1

### Turbo Features

- Gamma-Ti turbine wheel
- Dual ceramic ball bearing assembly with metal cage
- Forged milled extended tip compressor wheel
- Stainless steel turbine housing
- Water cooled bearing housing
- Large internal wastegate
- Compressor recirculation valve (a.k.a BOV)
- Boost control solenoid valve
- Standard T3 mounting flange

#### Not included with turbo assemblies:

- Speed sensor
- Turbine outlet V-Band
- Turbine inlet gasket
- Oil drain gasket or drain port fitting

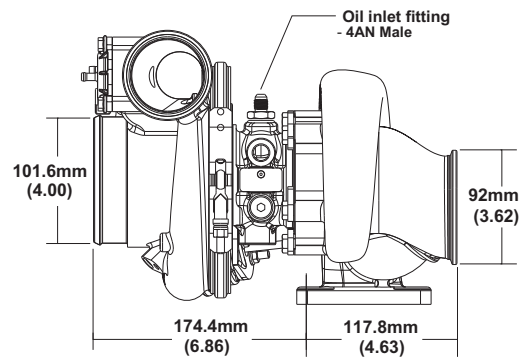

### Compressor Map

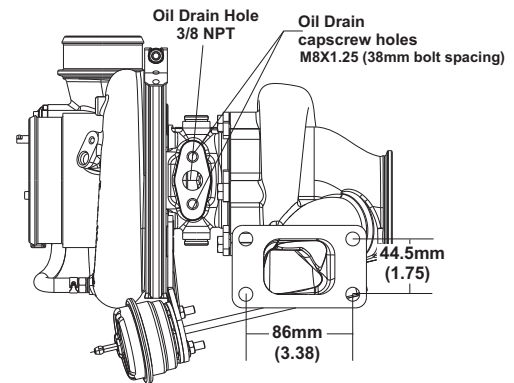
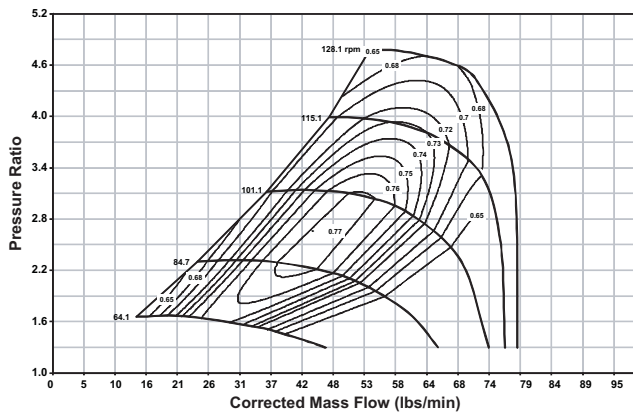

### Super Core Configuration

The following parts are not included as part of the super-core assembly: turbine housing, assembly clamp plate hardware, wastegate parts.

### Turbine Housing Options

Turbine Housing Part Number	A/R	Inlet Flange Shape	Housing Config.
12741019002	1.05	T4	Twin Scroll Non-WG

Turbo Part Number	Turbo Frame Size	Super Core Part Number	Comp. Wheel Outer Dia. (mm)	Comp. Wheel Inducer Dia.	Turbine Wheel Outer Dia.	Turbo A/R	Inlet Flange Config.
179258	B2	179257	83	62	74	.83	T3



### Turbo Frame Dimensions

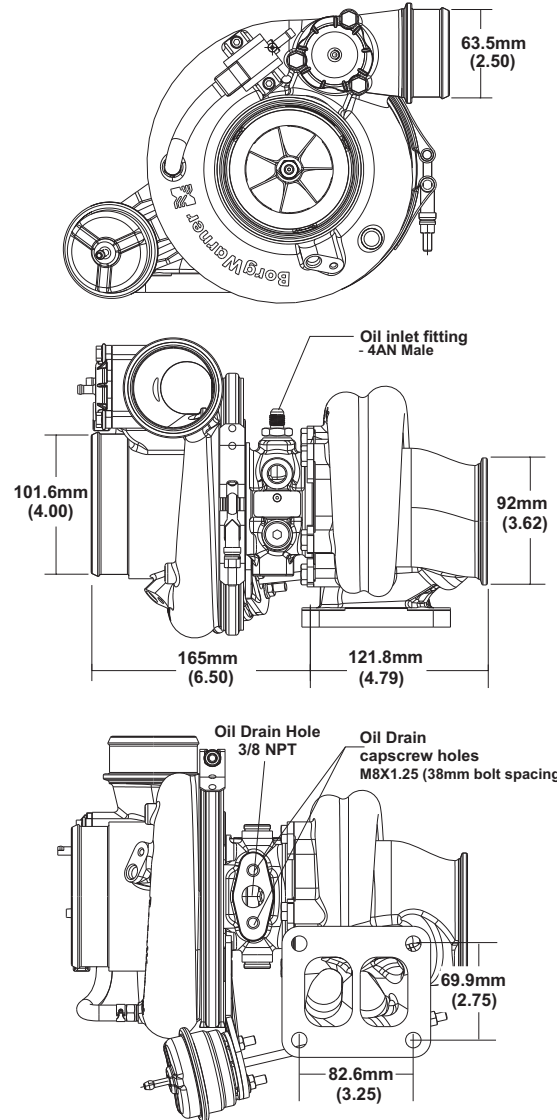

### Turbo Features

- Gamma-Ti turbine wheel
- Dual ceramic ball bearing assembly with metal cage
- Forged milled extended tip compressor wheel
- Stainless steel turbine housing
- Water cooled bearing housing
- Compressor recirculation valve (a.k.a BOV)
- Boost control solenoid valve
- Standard T4 mounting flange

#### Not included with turbo assemblies:

- Speed sensor
- Turbine outlet V-Band
- Turbine inlet gasket
- Oil drain gasket or drain port fitting

### Compressor Map

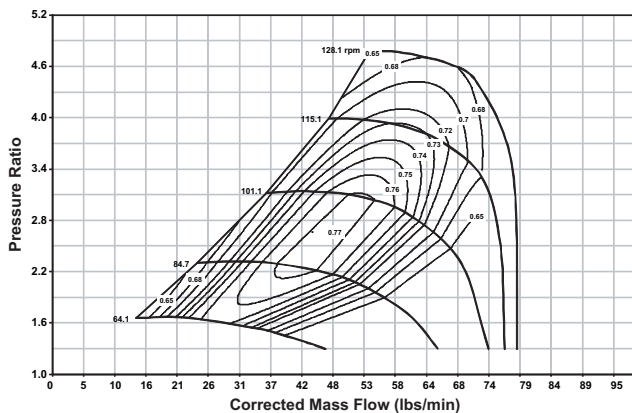

### Super Core Configuration

The following parts are not included as part of the super-core assembly: turbine housing, assembly clamp plate hardware, wastegate parts.

### Turbine Housing Options

Turbine Housing Part Number	A/R	Inlet Flange Shape	Housing Config.
12741008000	.83	T3	Single Scroll WG
12741008001	.92	T4	Twin Scroll WG
12741019002	1.05	T4	Twin Scroll Non-WG

Turbo Part Number	Turbo Frame Size	Super Core Part Number	Comp. Wheel Outer Dia. (mm)	Comp. Wheel Inducer Dia.	Turbine Wheel Outer Dia.	Turbo A/R	Inlet Flange Config.
179357	B2	179257	83	62	74	.92	T4



### Turbo Frame Dimensions

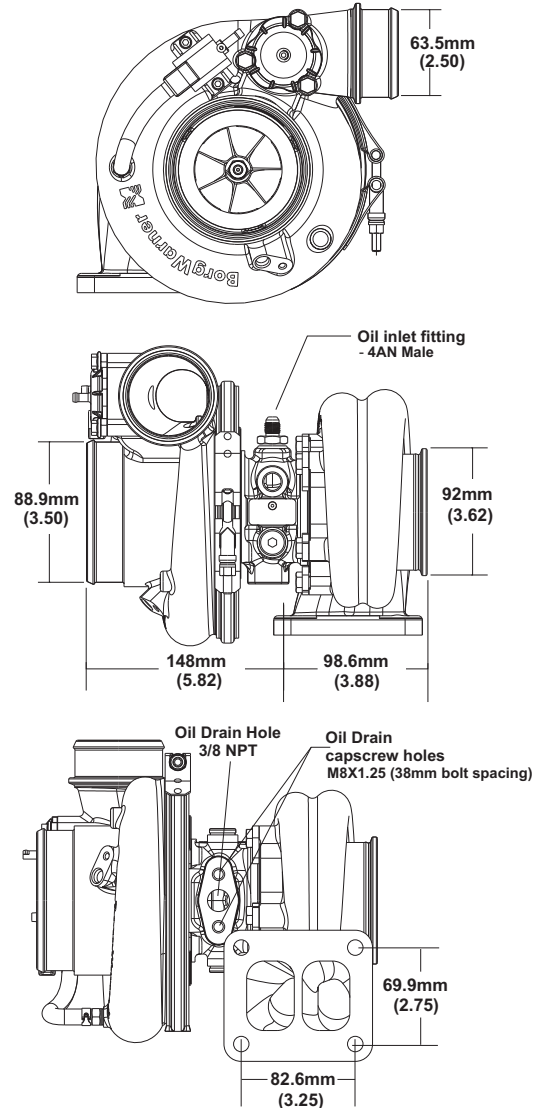

### Turbo Features

- Gamma-Ti turbine wheel
- Dual ceramic ball bearing assembly with metal cage
- Forged milled extended tip compressor wheel
- Stainless steel turbine housing
- Water cooled bearing housing
- Compressor recirculation valve (a.k.a BOV)
- Boost control solenoid valve
- Standard T4 mounting flange

#### Not included with turbo assemblies:

- Speed sensor
- Turbine outlet V-Band
- Turbine inlet gasket
- Oil drain gasket or drain port fitting

### Compressor Map

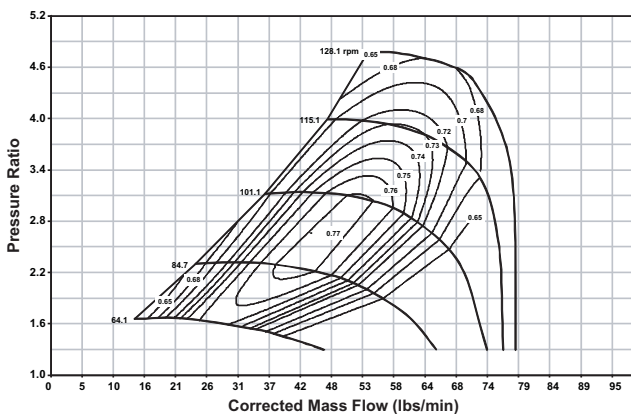

### Super Core Configuration

The following parts are not included as part of the super-core assembly: turbine housing, assembly clamp plate hardware, wastegate parts.

### Turbine Housing Options

Turbine Housing Part Number	A/R	Inlet Flange Shape	Housing Config.
12741008000	.83	T3	Single Scroll WG
12741008001	.92	T4	Twin Scroll WG
12741019002	1.05	T4	Twin Scroll Non-WG

Turbo Part Number	Turbo Frame Size	Super Core Part Number	Comp. Wheel Outer Dia. (mm)	Comp. Wheel Inducer Dia.	Turbine Wheel Outer Dia.	Turbo A/R	Inlet Flange Config.
179393	B2	179257	83	62	74	1.05	T4