

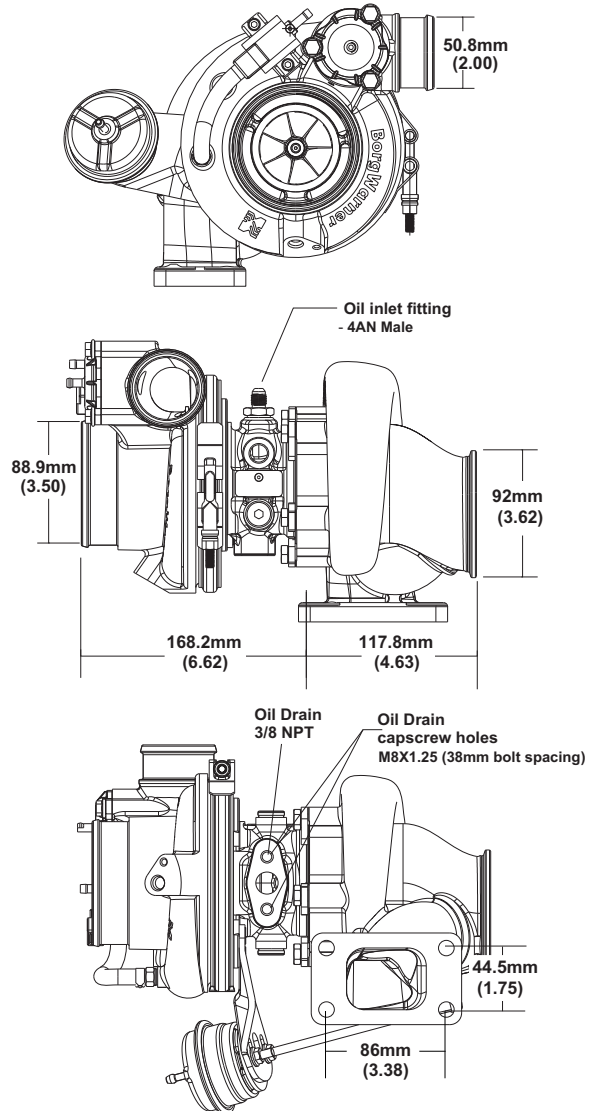

Turbo Frame Dimensions



Turbo Features

- Gamma-Ti turbine wheel
- Dual ceramic ball bearing assembly with metal cage
- Forged milled extended tip compressor wheel
- Stainless steel turbine housing
- Water cooled bearing housing
- Large internal wastegate
- Compressor recirculation valve (a.k.a BOV)
- Boost control solenoid valve
- Standard T3 mounting flange

Not included with turbo assemblies:

- Speed sensor
- Turbine outlet V-Band
- Turbine inlet gasket
- Oil drain gasket or drain port fitting

Compressor Map

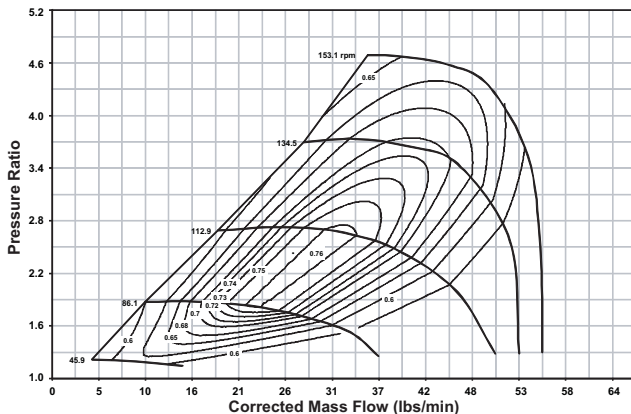

Super Core Configuration

The following parts are not included as part of the super-core assembly: turbine housing, assembly clamp plate hardware, wastegate parts.

Turbine Housing Options

Turbine Housing Part Number	A/R	Inlet Flange Shape	Housing Config.
12641008006	0.83	T3	Single Scroll WG
12641008007	0.92	T4	Twin Scroll WG
12641019016	1.05	T4	Twin Scroll Non-WG

Turbo Part Number	Turbo Frame Size	Super Core Part Number	Comp. Wheel Outer Dia. (mm)	Comp. Wheel Inducer Dia.	Turbine Wheel Outer Dia.	Turbo A/R	Inlet Flange Config.
179355	B2	179354	70	52	64	.83	T3



Turbo Frame Dimensions

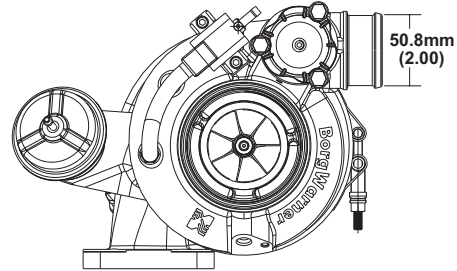

8

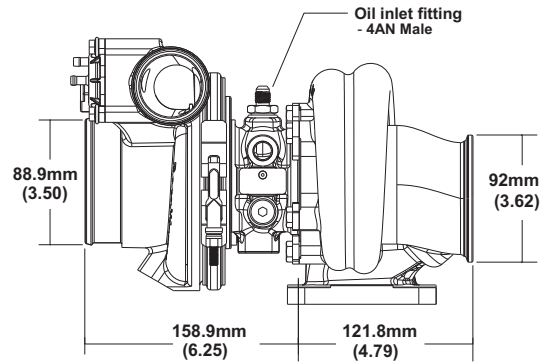

Turbo Features

- Gamma-Ti turbine wheel
- Dual ceramic ball bearing assembly with metal cage
- Forged milled extended tip compressor wheel
- Stainless steel turbine housing
- Water cooled bearing housing
- Large internal wastegate
- Compressor recirculation valve (a.k.a BOV)
- Boost control solenoid valve
- Standard T4 mounting flange

Not included with turbo assemblies:

- Speed sensor
- Turbine outlet V-Band
- Turbine inlet gasket
- Oil drain gasket or drain port fitting

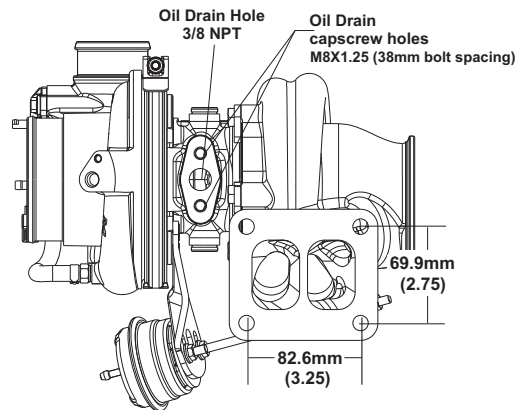

Compressor Map

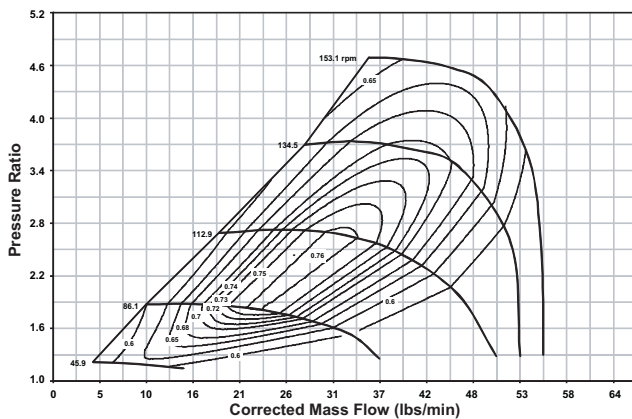

Super Core Configuration

The following parts are not included as part of the super-core assembly: turbine housing, assembly clamp plate hardware, wastegate parts.

Turbine Housing Options

Turbine Housing Part Number	A/R	Inlet Flange Shape	Housing Config.
12641008006	0.83	T3	Single Scroll WG
12641008007	0.92	T4	Twin Scroll WG
12641019016	1.05	T4	Twin Scroll Non-WG

Turbo Part Number	Turbo Frame Size	Super Core Part Number	Comp. Wheel Outer Dia. (mm)	Comp. Wheel Inducer Dia.	Turbine Wheel Outer Dia.	Turbo A/R	Inlet Flange Config.
179389	B2	179354	70	52	64	.92	T4

EFR 7064

300 - 500 HP Turbo



Turbo Frame Dimensions

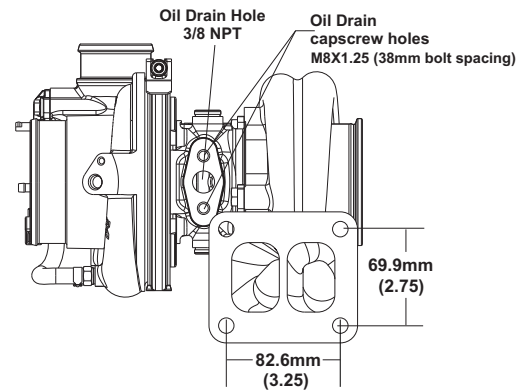
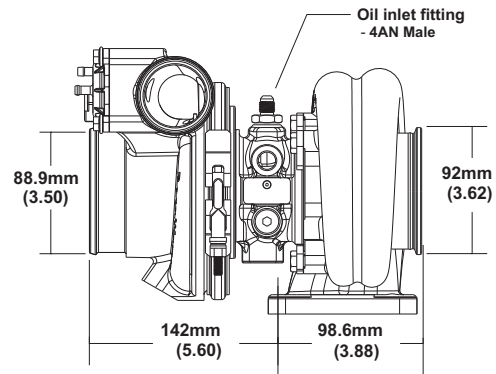
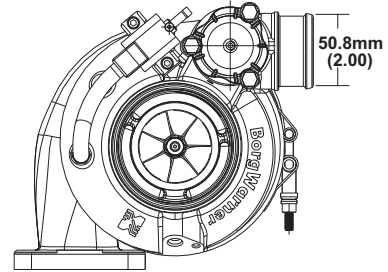

Turbo Features

- Gamma-Ti turbine wheel
- Dual ceramic ball bearing assembly with metal cage
- Forged milled extended tip compressor wheel
- Stainless steel turbine housing
- Water cooled bearing housing
- Compressor recirculation valve (a.k.a BOV)
- Boost control solenoid valve
- Standard T4 mounting flange

Not included with turbo assemblies:

- Speed sensor
- Turbine outlet V-Band
- Turbine inlet gasket
- Oil drain gasket or drain port fitting

Compressor Map

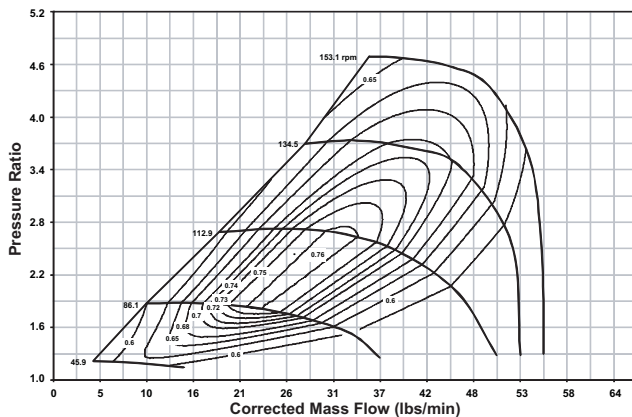

Super Core Configuration

The following parts are not included as part of the super-core assembly: turbine housing, assembly clamp plate hardware, wastegate parts.

Turbine Housing Options

Turbine Housing Part Number	A/R	Inlet Flange Shape	Housing Config.
12641008006	0.83	T3	Single Scroll WG
12641008007	0.92	T4	Twin Scroll WG
12641019016	1.05	T4	Twin Scroll Non-WG

Turbo Part Number	Turbo Frame Size	Super Core Part Number	Comp. Wheel Outer Dia. (mm)	Comp. Wheel Inducer Dia.	Turbine Wheel Outer Dia.	Turbo A/R	Inlet Flange Config.
179391	B2	179354	70	52	64	1.05	T4