

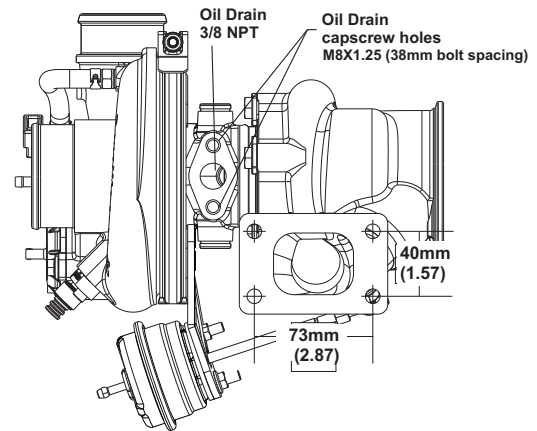

Turbo Frame Dimensions

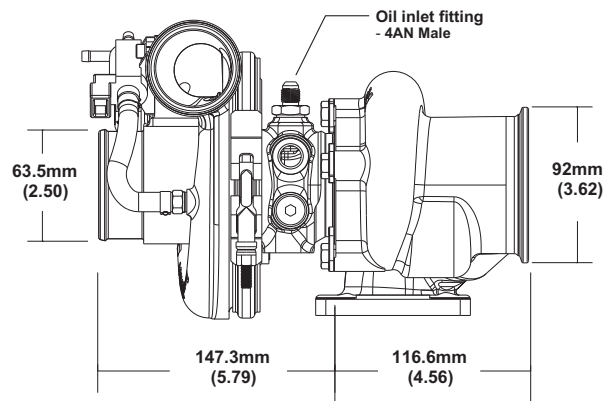
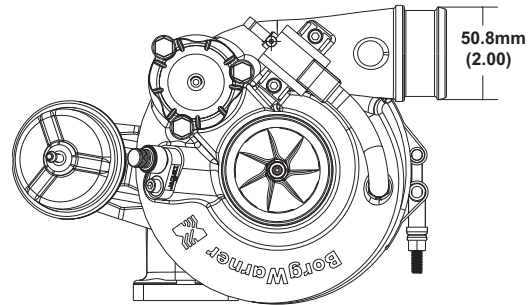

Turbo Features

- Gamma-Ti turbine wheel
- Dual ceramic ball bearing assembly with metal cage
- Forged milled extended tip compressor wheel
- Stainless steel turbine housing
- Water cooled bearing housing
- Large internal wastegate
- Compressor recirculation valve (a.k.a BOV)
- Boost control solenoid valve
- Standard T25 mounting flange

Not included with turbo assemblies:

- Speed sensor
- Turbine outlet V-Band
- Turbine inlet gasket
- Oil drain gasket or drain port fitting

Compressor Map

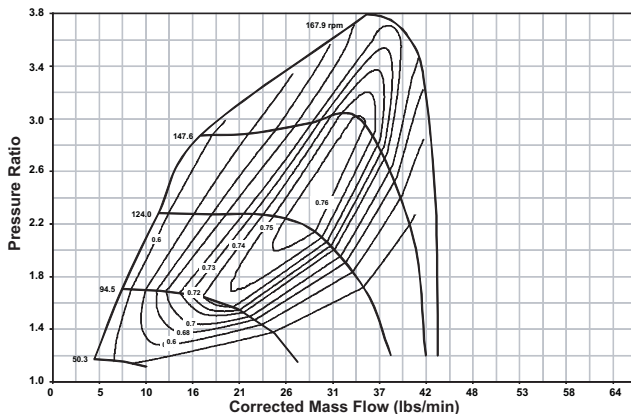

Super Core Configuration

The following parts are not included as part of the super-core assembly: turbine housing, assembly clamp plate hardware, wastegate parts.

Turbine Housing Options

Turbine Housing Part Number	A/R	Inlet Flange Shape	Housing Config.
11581009006	0.64	T25	Single Scroll WG
11581009007	0.92	T4	Twin Scroll WG

Turbo Part Number	Turbo Frame Size	Super Core Part Number	Comp. Wheel Outer Dia. (mm)	Turbo Inducer Dia.	Turbine Wheel Outer Dia.	Turbo A/R	Inlet Flange Config.
179150	B1	179140	62	49	58	.64	T25



Turbo Frame Dimensions

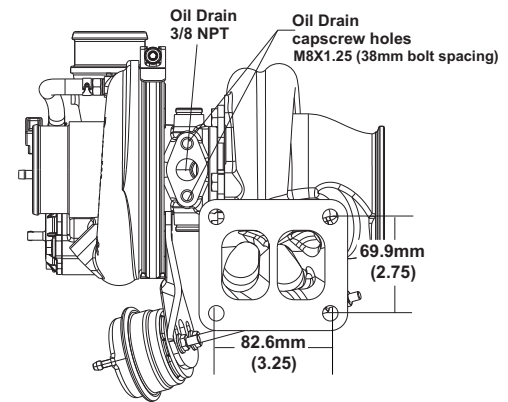
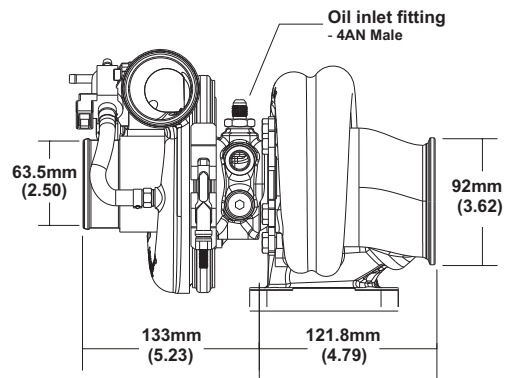
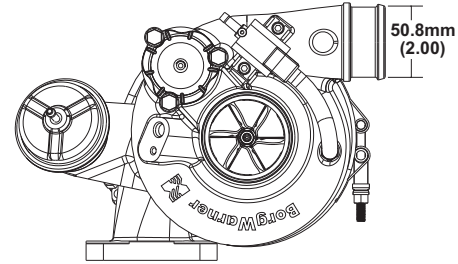

Turbo Features

- Gamma-Ti turbine wheel
- Dual ceramic ball bearing assembly with metal cage
- Forged milled extended tip compressor wheel
- Stainless steel turbine housing
- Water cooled bearing housing
- Large internal wastegate
- Compressor recirculation valve (a.k.a BOV)
- Boost control solenoid valve
- Standard T4 mounting flange

Not included with turbo assemblies:

- Speed sensor
- Turbine outlet V-Band
- Turbine inlet gasket
- Oil drain gasket or drain port fitting

Compressor Map

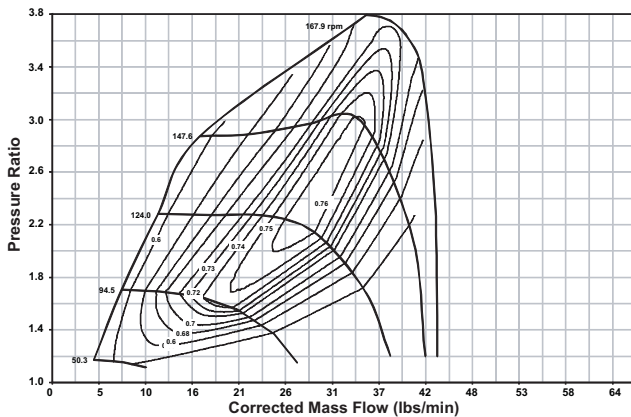

Super Core Configuration

The following parts are not included as part of the super-core assembly: turbine housing, assembly clamp plate hardware, wastegate parts.

Turbine Housing Options

Turbine Housing Part Number	A/R	Inlet Flange Shape	Housing Config.
11581009006	0.64	T25	Single Scroll WG
11581009007	0.92	T4	Twin Scroll WG

Turbo Part Number	Turbo Frame Size	Super Core Part Number	Comp. Wheel Outer Dia. (mm)	Comp. Wheel Inducer Dia.	Turbine Wheel Outer Dia.	Turbo A/R	Inlet Flange Config.
179359	B1	179140	62	49	58	.92	T4