

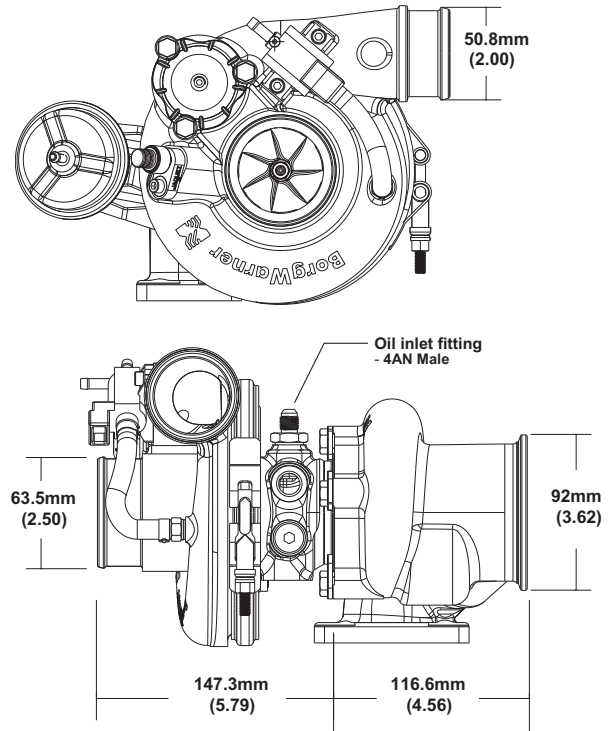

Turbo Frame Dimensions



Turbo Features

- Gamma-Ti turbine wheel
- Dual ceramic ball bearing assembly with metal cage
- Forged milled extended tip compressor wheel
- Stainless steel turbine housing
- Water cooled bearing housing
- Large internal wastegate
- Compressor recirculation valve (a.k.a BOV)
- Boost control solenoid valve
- Standard T25 mounting flange

Not included with turbo assemblies:

- Speed sensor
- Turbine outlet V-Band
- Turbine inlet gasket
- Oil drain gasket or drain port fitting

Compressor Map

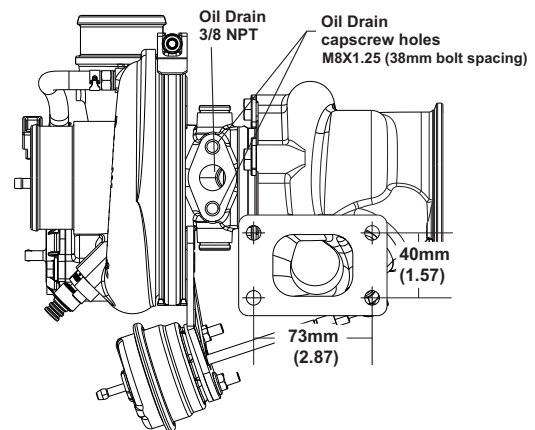
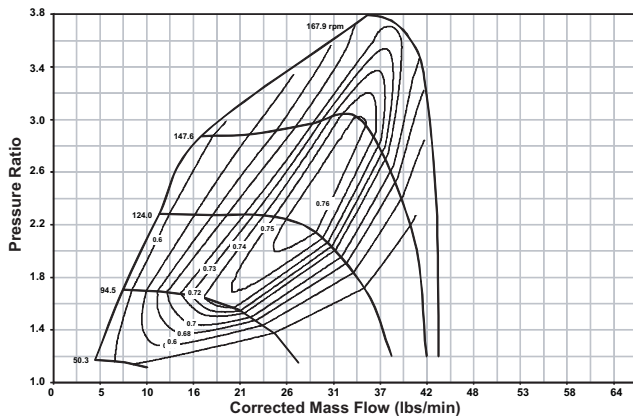

Super Core Configuration

The following parts are not included as part of the super-core assembly: turbine housing, assembly clamp plate hardware, wastegate parts.

Turbine Housing Options

Turbine Housing Part Number	A/R	Inlet Flange Shape	Housing Config.
11581009007	0.64	T25	Single Scroll WG

Turbo Part Number	Turbo Frame Size	Super Core Part Number	Comp. Wheel Outer Dia. (mm)	Comp. Wheel Inducer Dia.	Turbine Wheel Outer Dia.	Turbo A/R	Inlet Flange Config.
179149	B1	179139	62	49	55	.64	T25